

CLIFF

ISS	AMEND	DATE
1	REDRAWN	17/1/91
2	VARIANTS ADD	1/2/95
3	NOTE ADDED	1/3/95
4	CL1386 DELETE	13/10/97
5	ERR TOL WAS .2	17/11/98
6	▲ AMENDED	29/1/99
7	CL13845 ADDED	9/4/02

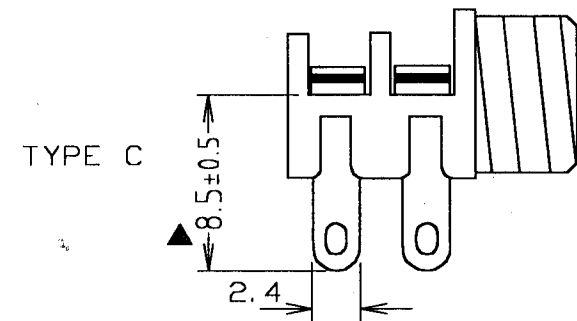
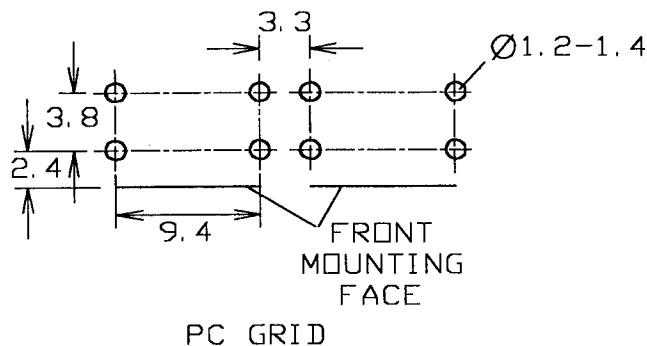
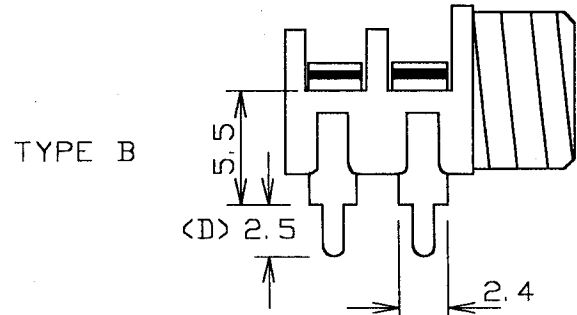
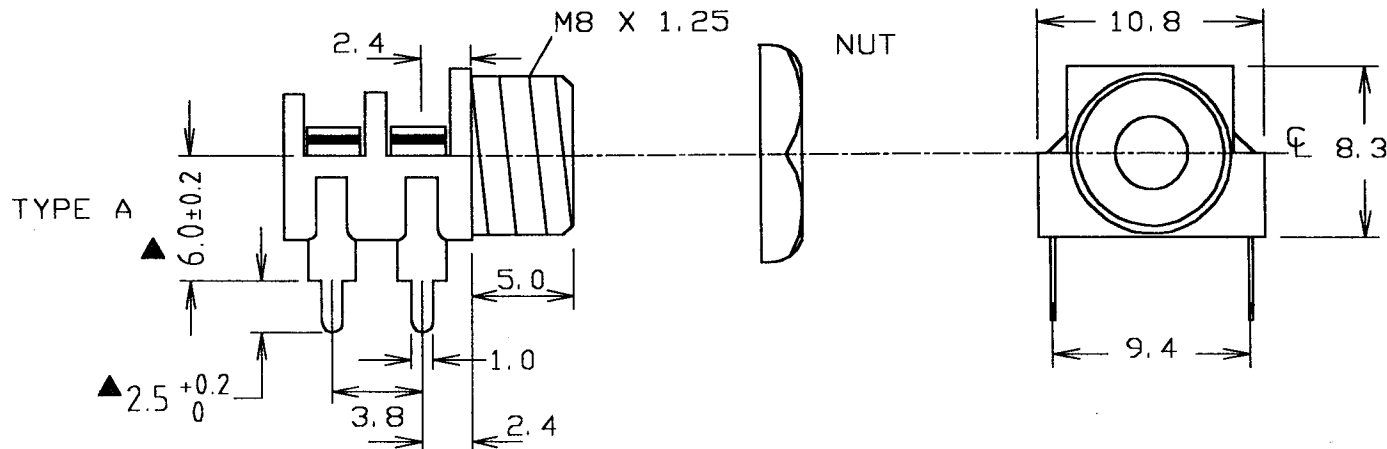

MAX PANEL THICKNESS 3.0mm.

NOTE: S6 SOCKETS ARE ONLY GUARANTEED TO PERFORM THE /SS FUNCTION. USERS REQUIRING 'B' OR 'M' FUNCTIONS MUST SATISFY THEMSELVES THAT THE PRODUCT IS SUITABLE FOR THEIR APPLICATIONS AND CLIFF ACCEPTS NO RESPONSIBILITY FOR USE OUTSIDE THE /SS FUNCTION.

▲ NOTE PARTS SUPPLIED TO ISSUE 5 UNTIL ISSUE 6 PARTS BECOME AVAILABLE.

VARIANTS

DESCRIPTION	P/No.	TYPE
S6/SS BLK UNASS	CL 1362	C
S6/SB BLK	CL 1366	C
S6/SB BLK CURLY REAR	CL 1367	C
S6/SB BLK PC	CL 1372	A
S6/SB BLK PC CURLY REAR W/O NUTS	CL 13735	A
S6/BB BLK	CL 1382	C
S6/BB BLK PC (GOLD)	CL 13829	A
S6/BB BLK TWEAKED FRONT	CL 138295	C
S6/BB BLK PC	CL 1384	A
S6/BB BLK PC CURLY REAR	CL 13841	A
S6/BB BLK PC CURLY REAR W/O NUTS	CL 13842	A
S6/BB BLK PC N/N SPECIAL 5.5	CL 13843	B
S6/BB BLK PC SPECIAL 5.5	CL 13844	B
S6/BB BLK PC 5.5 / CURLY CONTACT	CL 13845	B
S6/BB BLK PC W/O NUTS	CL 1385	A
S6/MB BLK	CL 1388	C
S6/MB PC	CL 1389	A
S6/MM BLK	CL 1390	C
S6/MM/PC BLK	CL 1391	A
S6/MM/M PC CUSTON (D=2.7)	CL 1392	D

Tolerance

NO DEC. PLACE ±

1 DEC. PLACE ± 0.15

2 DEC. PLACE ±

DIA. HOLES ±

ANGLES ± 1/2°

UNLESS OTHERWISE STATED

WHERE USED F.R.

SCALE N.T.S.

DIMENSIONS IN MILLIMETERS UNLESS OTHERWISE STATED. WORK TO DIMENSIONS. DO NOT SCALE DRAWING. 3rd ANGLE PROJECTION. REMOVE BURRS. IF IN DOUBT ASK.

Cliff Electronic Components, Inc.
 4876 East Second Street, Benicia, CA 94510 USA
 Tel: (707) 746 8090 Fax: (707) 746 8092

MATERIAL	PBT / NIAG
FINISH	AS MOULDED / NATURAL
DRAWN	C.A.M.J.
APPD.	RWT

TITLE	S6 MINIATURE JACK SOCKET
DRWG. No.	CL 1362/1392
FORM:	A4DRWGH